

# Solid carbide radius milling cutter

**K.-H. Müller Präzisionswerkzeuge GmbH**  
Fürst-Dominik-Str.44, 55758 Sien, GERMANY  
Phone: +49 (0) 6788/9798-0  
Fax: +49 (0) 6788/9798-99  
email: info@mueller-sien.de

Company: \_\_\_\_\_

Customer no.: \_\_\_\_\_

Contact person: \_\_\_\_\_

Phone: \_\_\_\_\_

Address: \_\_\_\_\_

Fax: \_\_\_\_\_

Email: \_\_\_\_\_

Quantities: \_\_\_\_\_

Offer needed by: \_\_\_\_\_

### Kind of machining:

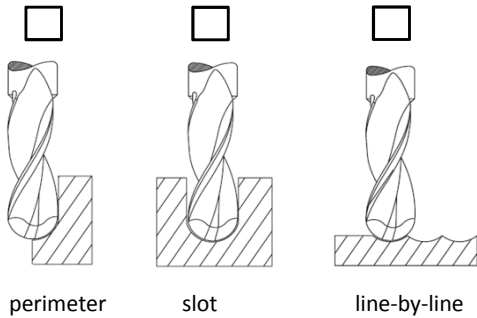

ap= \_\_\_\_\_

ae= \_\_\_\_\_

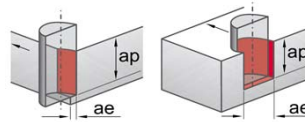

### Material to be machined:

Material name: \_\_\_\_\_

Strength: \_\_\_\_\_

Hardness: \_\_\_\_\_

Surface: \_\_\_\_\_

Pre-machined: \_\_\_\_\_

number of teeth:  2     3     4     \_\_\_\_

spiral angle:  0°     30°     40°     \_\_\_\_

cutting direction:  right     left

perimeter profile:  roughing     finishing

kind of coolant:  oil     emulsion     minimum lubrication     dry

cooling:  internal     external     other

shank:  HA     HB     HE     other

current tool: \_\_\_\_\_

reason for changing: \_\_\_\_\_

Vc: \_\_\_\_\_

feed: \_\_\_\_\_

machine: \_\_\_\_\_

chucking: \_\_\_\_\_

coating: \_\_\_\_\_

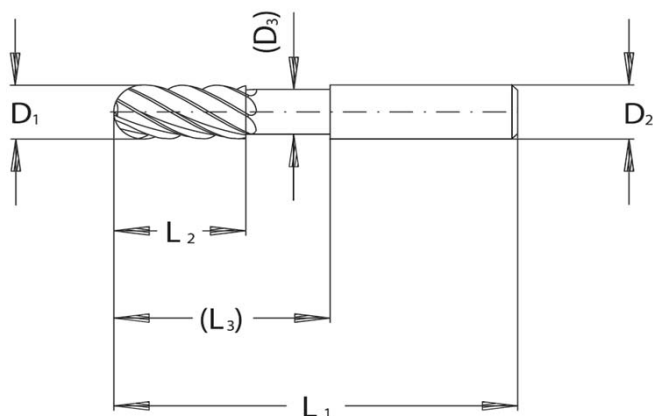

D1= \_\_\_\_\_ tol.: \_\_\_\_\_      L1= \_\_\_\_\_ tol.: \_\_\_\_\_

D2= \_\_\_\_\_ tol.: \_\_\_\_\_      L2= \_\_\_\_\_ tol.: \_\_\_\_\_

(D3)= \_\_\_\_\_ tol.: \_\_\_\_\_      (L3)= \_\_\_\_\_ tol.: \_\_\_\_\_

additional information: \_\_\_\_\_